

## Club News

The May business meeting will be held on Thursday the 6th at Obie's Trains in Alexandria. We'll be discussing the possible purchase of a Club throttle like the one we were using at the Greenberg show or like the one that Dennis Austin ran at the February setup.

The Greenberg show was a big success! Thanks to all who attended, brought modules, and helped with setup and tear-down. We had a great location, over 110' of mainline, and lots of visitors. Northern Virginia N-Trak is developing a strong reputation as a quality organization with skilled and knowledgeable modelers. In fact, the March/April *N Scale* Magazine has a feature story on gorge modules with our Club's president's module prominently pictured. Dennis Austin is just one of many Northern Virginia N-Trak members who have been featured in our hobby publications. Others who have been recognized include Monroe Stewart's Hooch Junction Railroad, Matt Schaefer's New River Gorge module, and Gil Brauch's new module.

The creativity of our members is impressive. For those of you who have not taken the plunge by building a module, consider talking with some of our members to get ideas and tips. You'd be surprised how much you can do with a little help from fellow Club members.

## Other N-Trak News

### Valley Forge Annual Convention

The 1993 NMRA Convention Headquarters is in the Valley Forge Sheraton Plaza, from August 1 through August 8. Although rooms are \$81 plus 8% tax, there are benefits in roosting in the convention hotel. The Valley Forge NTRAK and NMRA Conventions have a combined \$65 basic registration fee that is much less

than previous conventions. Separate daily rates are \$25 for one day and \$50 for two days.

Anyone can bring modules for anyone else and they will be included if there is room. At this time 700 feet of modules have registered and there is only room for 1200 feet. They prefer three foot corners and request that a module description form be sent in as early as possible. They really need inside corners. It is estimated that a single trip around the layout will take 1-1/4 hour. On Saturday, they plan to run 12 simultaneous 100-car trains. They expect to run 20-car passenger trains, too. 24 operators are needed for the simultaneous session.

If Northern Virginia N-Trak members want to have modules that stand out, some integration of scenery, industry, separate loop, or operation between flyovers should be considered. Contact Matt Schaefer if you have any recommendations. The Point of Contact for information and module registration is Dave Savage, Coordinator, 220 S. Bishop Ave., Secane, PA 19018.

*For those of you who were not aware, there is a national NTRAK organization. A bimonthly newsletter is published with lots of info on N-Scale activities. There are also NTRAK resource booklets covering everything from module construction to throttles. You can join by sending \$5.00 to: NTRAK Publishing, 2424 Alturas Rd., Atascadero, CA 93422, (805)466-1758. Jim FitzGerald runs the organization and handles the newsletter.*

## Railfan News

Norfolk Southern steam fans will be interested in the Oak Ridge Railroad Festival on May 15 and 16 from 10 a.m. to 5 p.m. at Oak Ridge Estate in Nelson County, Virginia to celebrate the memory of Thomas Fortune Ryan. The Festival will feature food and wine vendors, exhibits, demonstrations, and tours of the restored Oak Ridge mansion.

The railroad tracks were built by the Orange and Alexandria Railroad in 1850. In the 1890s, the Southern Railroad took over the O&A. Thomas Ryan was one of

## More containers for your money

The Interail container kit (59451.00) provides an excellent opportunity for N scale modelers to inexpensively expand their stock of ISO containers. With a small investment in Evergreen board and batten styrene sheet stock (Walthers 269-4542) and dimensional strip 0.040"x 0.040" you can double the number of containers you get from one kit. If you have purchased an Interail kit (Obie's Trains sells them for \$2.99; compare that to about \$6.00 for three Concor 40' or 45' containers, or \$4.50 for 6 20' Model Power containers) you will notice that the kit comes with enough sides, tops, and bottoms for two forty foot containers. However, the kit also provides end pieces for two additional containers.

The board and batten sheet stock gives you an accurate model of a corrugated style container. Though once available, models of these are out of production right now. Kit bashing is the only way to get these attractive containers for your layout.

Using pieces from these kits as templates, you can cut side panels from the board and batten styrene. File the third rib in from the end on each side of the side panel. Add dimensional strips to the cut panels to represent the reinforced frame. Cut a top and bottom from the sheet styrene again using the kit parts as a template. The ribs on these pieces will face inside. Using the excess end pieces from the kit, assemble the cut pieces as you would one of the containers from the kit. Viola, you now have a fit-bashed container! Put one ounce of lead in containers that will be on the bottom of a double stack, but leave the the containers intended for the top empty.

*(Continued on reverse)*

*Deadline for article and announcement submissions for newsletter is the 15th of the preceding month. Newsletter is mailed last week of the preceding month.*

Most shipping companies use corrugated containers. Typically they are painted box car red or orange. The paint usually appears quite faded. Decals are available from Microscale for numerous different container logos, including Genstar, APL, and Evergreen. Don't forget the weathering. The corrugated ribs look great with a black wash and some pastel chalk dust.

Using this technique it shouldn't be long before we have a long, heavy double stack train with several modern engines on point cruising the rails of our set-ups.

(Contributed by Bernie Kempinski)

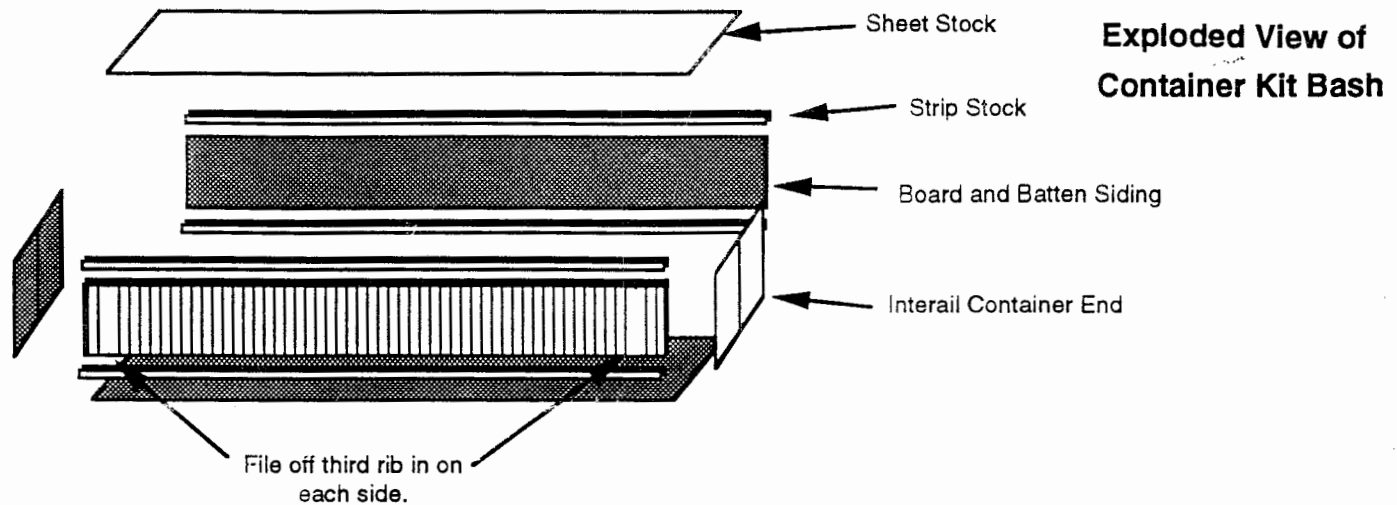

the creators of the Southern RR. He built his own station next to the tracks on his estate to more easily travel between his New York and Shipman homes. Ryan and his first wife owned individual Pullman cars. Ryan's was called the Oak Ridge and his wife's was the Pere Marquette.

More than three miles of double-track mainline runs through the 5,000 acre estate and is still used by Amtrak and Norfolk Southern. This will be the first time in 20 years since a train has stopped at the Oak

Ridge station. Round trip fares for the ride (if any are still available!) from Alexandria to Oak Ridge then Lynchburg and back to Alexandria range from \$69 to \$189. Admission to the festival is \$3. For more information, contact Lee Marmon at 804-263-4168.

#### Meeting Reminders

**May 6** 7:00 pm May business meeting at Obie's Trains, 6464 Edsall Road, Alexandria (behind the Quality Inn).

**May 16** Monthly setup at the Fairfax Fire Training Academy from 2 p.m. until 8 p.m. Bring some money and we'll all order pizza.

Northern Virginia NTRAK Officers:  
 President: Dennis Austin, 703-444-7198  
 Secretary: Chris Riddick, 703-437-9247  
 Treas.: Edd Braithwood, 703-860-2899  
 Sprntndnt: Matt Schaefer, 703-978-2946